

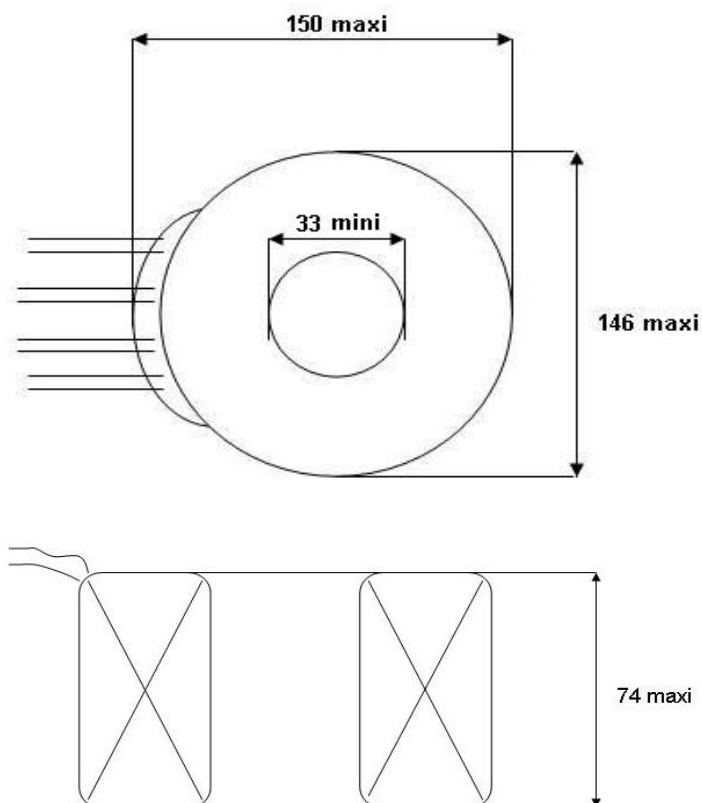

**DESCRIPTION : Toroidal Transformer 400 VA**

Mechanical schematics



Electrical schematics

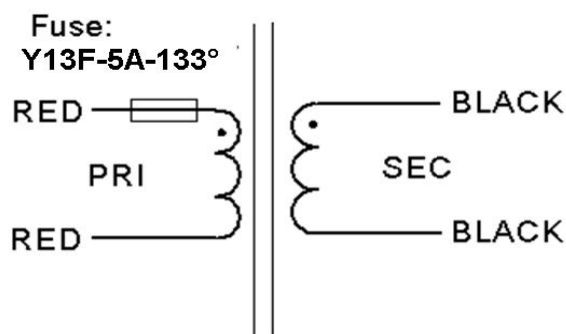

**ELECTRICAL DATA**

PN	VOLTAGE		NO LOAD VOLTAGE	SECONDARY CURRENT	Ambiant T° T° class	POWER
	PRIMARY	SECONDARY				
S30400B1006	1X230V	1X6V	6,14 V	1X66,67A	Ta 50/b	400VA
S30400B1009		1X9V	9,5 V	1X44,44A		
S30400B1012		1X12V	12,28 V	1X33,33A		
S30400B1015		1X15V	15,52 V	1X26,67A		
S30400B1018		1X18V	18,47 V	1X22,22A		

GENERAL CHARACTERISTICS	ACCESSORIES	PRINTING
<ul style="list-style-type: none"> <li>- Safety transformers, compliant with NF EN61558</li> <li>- UL components</li> <li>- Protection rating : IP00</li> <li>- Approximate weight : 350 g</li> </ul>	<ul style="list-style-type: none"> <li>- 1 Metal washer - Ø int 8 mm</li> <li>- 2 Rubber washer Ø int 8 mm</li> <li>- 1 Screw M8</li> <li>- 1 Hex nut M8</li> <li>- 2 Washers Ø 8 mm</li> </ul>	<ul style="list-style-type: none"> <li>- TPE (TECH POWER ELECTRONICS)</li> <li>- PN</li> <li>- DATE CODE</li> <li>- VOLTAGE</li> <li>- POWER</li> <li>- EN 61558</li> </ul>