

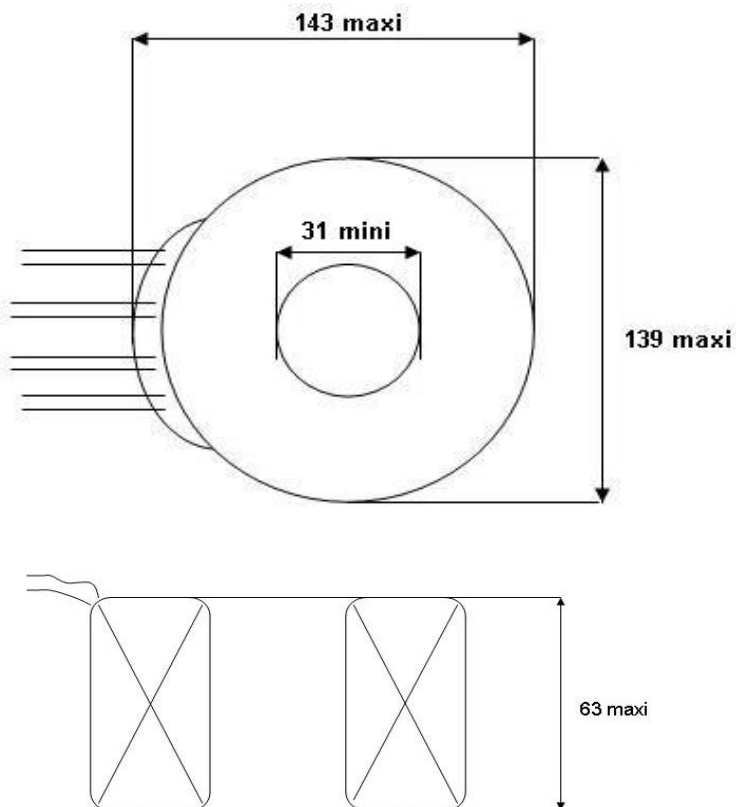

DESCRIPTION : Toroidal Transformer 300 VA

Mechanical schematics



Electrical schematic

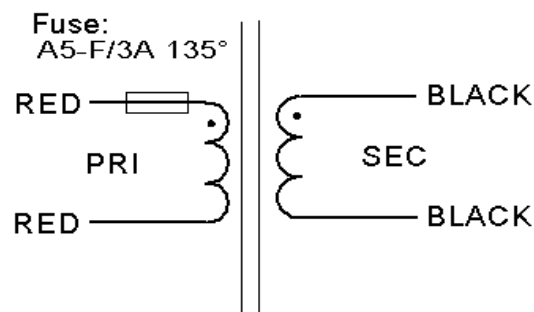

ELECTRICAL DATA

PN	VOLTAGE		NO LOAD VOLTAGE	SECONDARY CURRENT	Ambiant T° T° class	POWER
	PRIMARY	SECONDARY				
S30300B1006	1X230V	1X6V	6,08 V	1X50A	Ta 50/b	300VA
S30300B1009		1X9V	9,55 V	1X33,33A		
S30300B1012		1X12V	12,15 V	1X25A		
S30300B1015		1X15V	15,62 V	1X20A		
S30300B1018		1X18V	18,66 V	1X16,67A		

GENERAL CHARACTERISTICS

- Safety transformers, compliant with NF EN61558
- UL components
- Protection rating : IP00
- Approximate weight : 350 g

ACCESSORIES

- 1 Metal washer - Ø int 8 mm
- 2 Rubber washer Ø int 8 mm
- 1 Screw M8
- 1 Hex nut M8
- 2 Washers Ø 8 mm

PRINTING

- TPE (TECH POWER ELECTRONICS)
- PN
- DATE CODE
- VOLTAGE
- POWER
- EN 61558