

**DATA SHEET**

**PN : SCN480V150**

**By Tech Power electronics**

**DESCRIPTION : Nanocrystalline toroidal common mode choke  
2x48 mH - 15A**

**MECHANICAL DIMENSIONS (mm)**

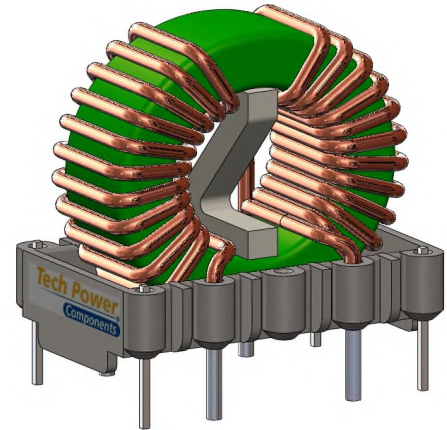
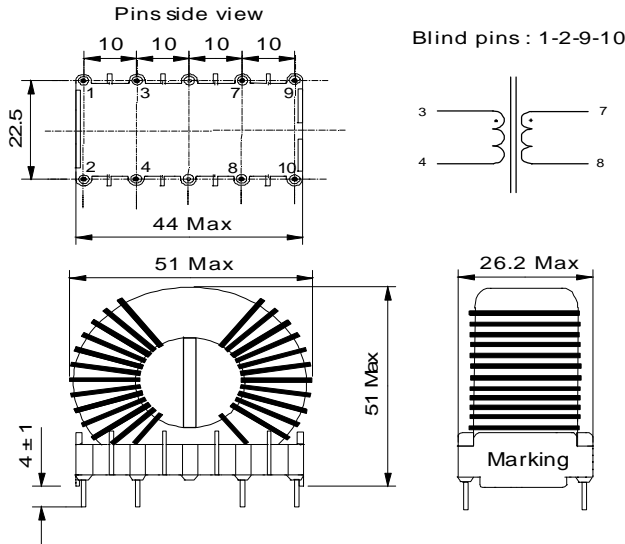

Ø Pin 1,32mm Cu tinned : Implantation in holes Ø 1,6  
Blind pins Ø 0,63: Implantation in hole Ø 1,2

m ≈ 105 g

**ELECTRICAL PROPERTIES**

MEASUREMENT CONDITIONS	CHARACTERISTICS	VALUE	UNIT	TOLERANCE
10kHz 10mV	Inductance	48	mH	± 40 %
100kHz 10mV	Inductance	10	mH	± 40 %
25°C	Resistance	14,5	mΩ	Typ.
< 70°C	Nominal Current	15	A	
50Hz	Rated Voltage	250	V	

Ambient temperature Ta = - 40° C to + 70° C  
Max. operating temperature = 130° C  
Data derating in case of deviant ambient temperatures or deviant nominal currents

**OTHER PROPERTIES**

APPROVALS	TEST CONDITIONS			
UL94 V-0 IEC60938-2 (VDE565-2-1)	Humidity : 33 % Temperature : 25°C Withstanding Voltage : 1500 Vac			
		Creation	1	12/07/11
		Modification	Number	Date