

**DATASHEET**

**PN : SCF056V025**

**By Tech Power electronics**

**DESCRIPTION : TOROIDAL COMMON MODE CHOKE  
2 X 5,6 mH - 2,5A**

MECHANICAL DIMENSIONS (mm)

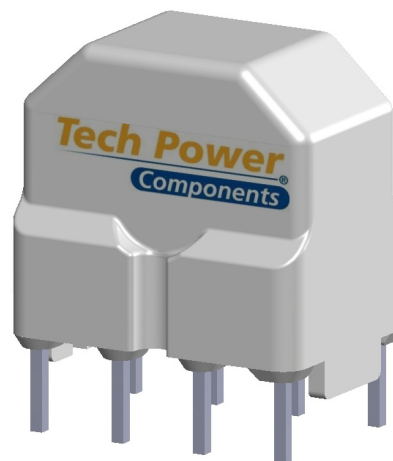
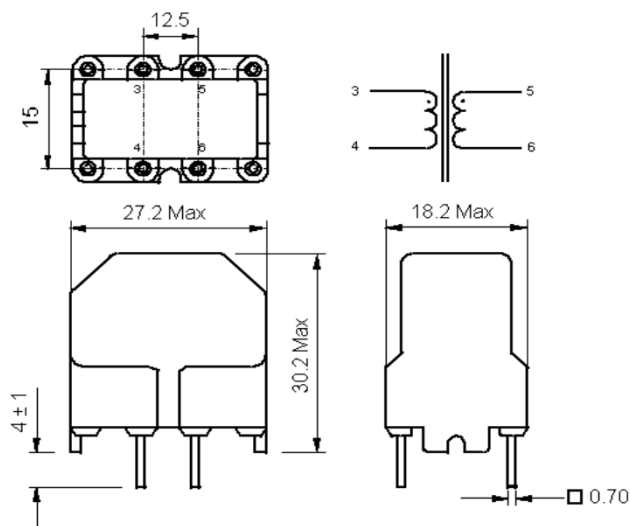

Implantation in holes Ø 1,3

**ELECTRICAL PROPERTIES**

MEASUREMENT CONDITIONS	CHARACTERISTICS	VALUE	UNIT	TOLERANCE
10kHz 10mV	Inductance	5,6	mH	+ 50 % / -30%
25°C	Resistance	105	mΩ	± 15%
< 60°C	Nominal Current	2,5	A	
50Hz	Rated Voltage	250	V	

**OTHER PROPERTIES**

APPROVALS	TEST CONDITIONS	RoHS COMPLIANT		
UL94 V-0 IEC60938-2 (VDE565-2-1) Climatic Class : 40/125/21 Operating temperature : -40°C to +125°C	Humidity : 33 % Temperature : 25°C Withstanding Voltage : 1500 Vac	Creation	1	12/07/11
		Modification	Number	Date