

PN : BJHCS-LTS

IPN = 6A - 15A - 25A - 50A

Features

- Closed loop
- High accuracy
- Small PCB mounting
- Very good linearity
- Low power consumption
- Good over-current capability
- Supply voltage : +5V DC
- Voltage output
- Through hole primary
- Can be customized

Applications

- Frequency drive control home appliances
- Solar power management system
- Inverter applications
- Uninterruptible power supplies (UPS)
- Current monitoring



ELECTRICAL DATA

BJHCS-LTS-...	6A	15A	25A	50A
Nominal rms current I_{PN} (A)	6	15	25	50
Sensed current range I_{PM} (A)	$\pm 19,2$	± 48	± 80	± 150
Measuring resistance R_M (Ω)	100	50	50	25
Number of secondary turns	960 ± 1	1200 ± 1	2000 ± 2	2000 ± 2
Rated output voltage V_O (V)	$V_{OE} \pm 0,625$			
Supply voltage V_C (Vdc)	$+5 \pm 5\%$			
Static current consumption I_{CO} (mA)	10			

ACCURACY DYNAMIC PERFORMANCE

GENERAL & ISOLATION CHARACTERISTICS

Overall accuracy X_G @ I_{PN} , $T=25^\circ\text{C}$	$\pm 0,7$	%	Operating temperature	-40 to +85	$^\circ\text{C}$
Zero offset voltage V_{OE} @ $I_P=0$, $T=25^\circ\text{C}$	$2,5^{\pm 20\text{mV}}$	V	Storage temperature	-40 to +125	$^\circ\text{C}$
Offset voltage drift	$\leq \pm 0,5$	mV/ $^\circ\text{C}$	Weight	10	g
Linearity error ϵ_L	$\leq 0,1$	% FS	Insulation voltage (50Hz, 1mn)	3	KV
di/dt accurately followed	> 50	A/ μs	Creepage distance (shell)	15,4	mm
Response time t_r	< 1	μs	Impulse withstand voltage (1,2/50 μs)	> 8	KV
Bandwidth (-1db)	DC to 200	Khz			

DIMENSIONS

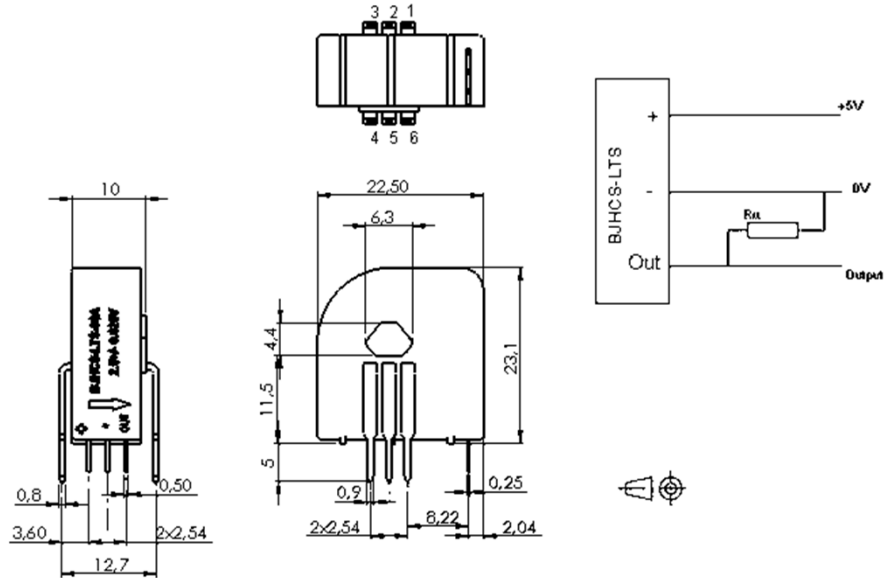

WIRING DIAGRAM

Cable hole current (N ^{ber} primary turns)	Nominal current LTS-...				Output rated (V)	Primary (mΩ)	Primary (μH)	PCB current input (Input Pin Connection)
	6A	15A	25A	50A				
1	±6	±15	±25	±50	2,5 ± 0,625	0,18	0,013	in 6—5—4 1—2—3 out
2	±3	±7,5	±12,5	±25	2,5 ± 0,625	0,81	0,05	in 6—5—4 1—2—3 out
3	±2	±5	±8,3	±16,6	2,5 ± 0,625	1,62	0,12	in 6—5—4 1—2—3 out

Cautions :

- I_s is positive when I_p flows in accordance with the arrow direction (see the side of the sensor);
- Primary conductor temperature should not exceed 100°C
- Best dynamic performances (di/dt and response time) are achieved with a single electrical conductor completely filling the through hole;
- To achieve the best magnetic coupling, the primary winding must be wound around the top edge of the sensor.

WARNING : Incorrect wiring may cause damage to the sensor.

BJHCS-LTS-25A : Relation between Input Current and Output voltage :

Input current (A)	- 80	- 75	- 50	- 25	0	25	50	75	80
Output voltage (V)	0,5	0,625	1,25	1,875	2,5	3,125	3,75	4,375	4,5

